



# INSTALLATION INSTRUCTIONS

Accessory  
ATF COOLER KIT

Application  
2016 MDX 4WD only

Publications No.  
**VERSION 2**  
Issue Date  
**MAR 2015**

## PARTS LIST

ATF Cooler

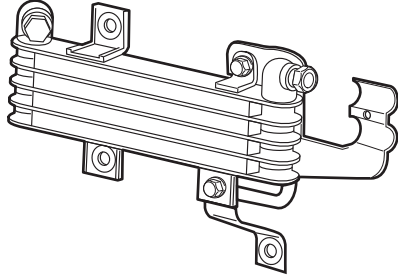

ATF Hose A

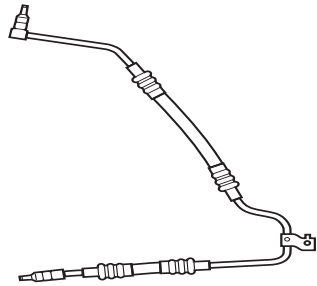

ATF Hose B

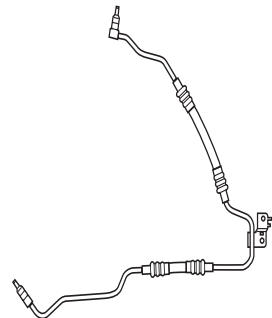

ATF Pipe A



ATF Pipe B



Washer Bolt (3) (6 x 20 mm)

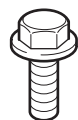

Washer Bolt (2) (6 x 16 mm)



Washer Bolt (3) (6 x 12 mm)



Transmission Hose Bracket

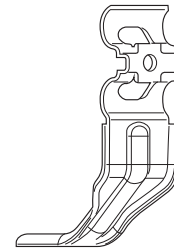

Hose Bracket (2)



Torx Bolts (4)



Fixing Plates (4)



Protective Sleeves (4)

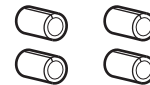

Hang-Tag

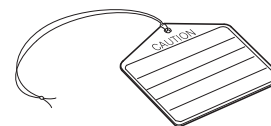

Label



## REQUIRED SPECIAL TOOLS

10 mm socket  
8 mm Hex socket  
T30 Torx socket  
Philips screwdriver

The following tools are available through the Honda Tool and Equipment Program. On the iN, click on: Service > Service Bay > Tool and Equipment Program, then enter the number under "Search." Or, call 888-424-6857.

- Trim Tool Set (T/N SOJATP2014)
- Clip Pliers (T/N 07AAC-001A100)

## INSTALLATION

**Client Information:** The information in this installation instruction is intended for use only by skilled technicians who have the proper tools, equipment, and training to correctly and safely add equipment to your vehicle. These procedures should not be attempted by "do-it-yourselfers."

NOTE: Allow the engine and transmission to cool down before installing the ATF cooler.

1. Remove the front bulkhead cover, resonator, and intake air guide.

### FRONT BULKHEAD COVER

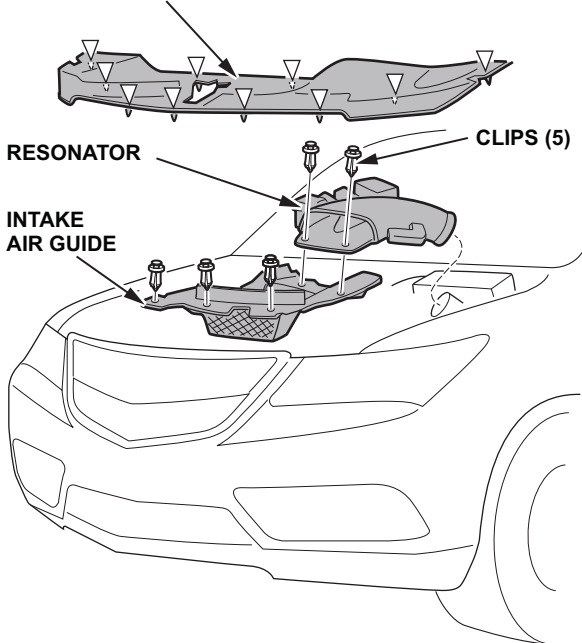

2. Remove the transmission fluid warmer bolts.  
NOTE: Do not disconnect the water bypass hoses.

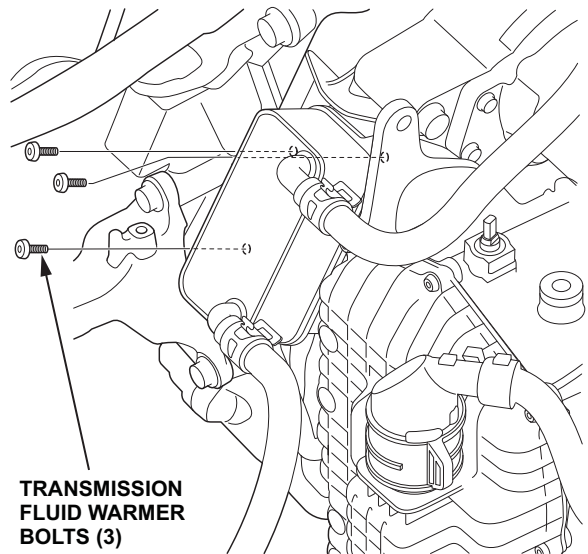

3. Remove the splash shield and fold down the front bumper skid trim.

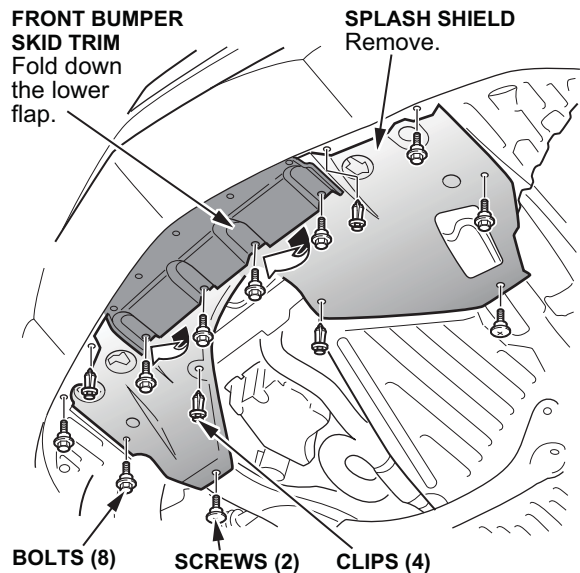

- Remove the lower air guide.

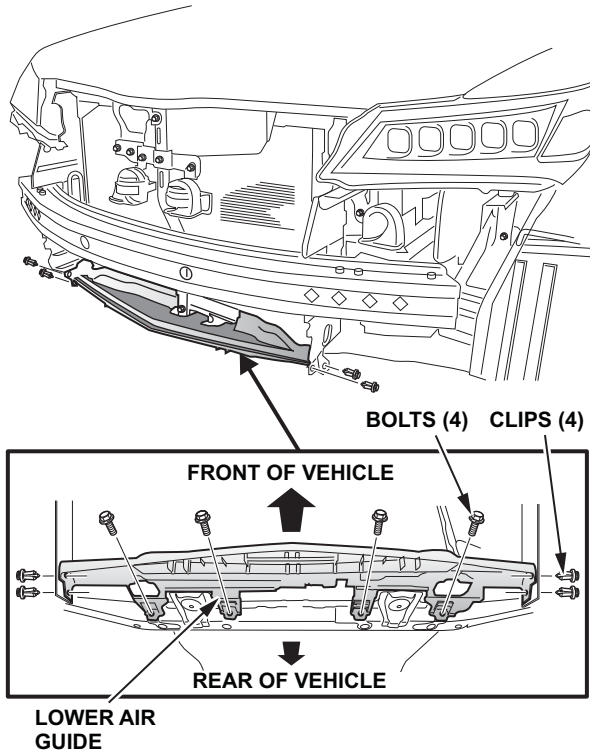

- Remove the front bumper center lower grille  
NOTE: If equipped, remove the parking sensor sub harness clamps.

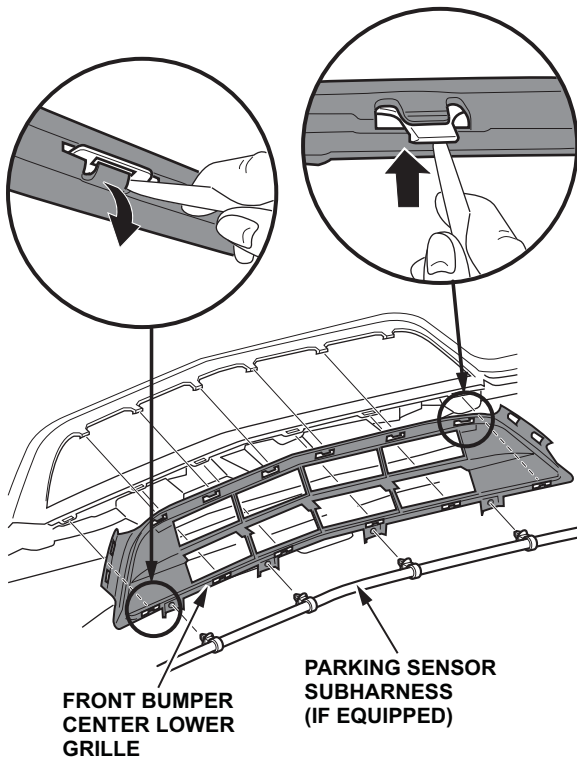

- Clean the connection points around the transmission fluid warmer pipes, then remove the transmission fluid warmer pipes and fixing plates.

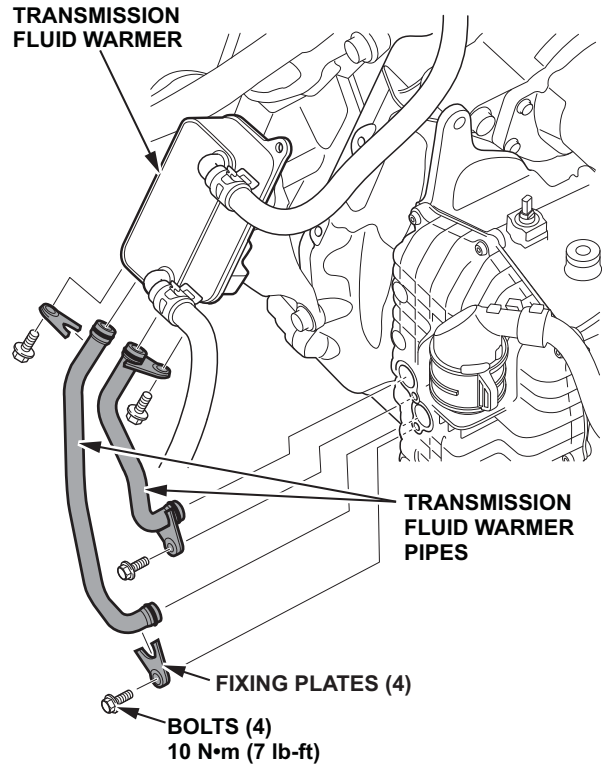

7. Make sure the connection points are clean and free of debris, then install ATF pipe A and ATF pipe B using the new fixing plates and Torx bolts supplied in this kit.  
NOTE: Don't clean or lubricate the o-rings, they are lubricated when shipped. Don't allow any other fluids to come in contact with the o-rings.

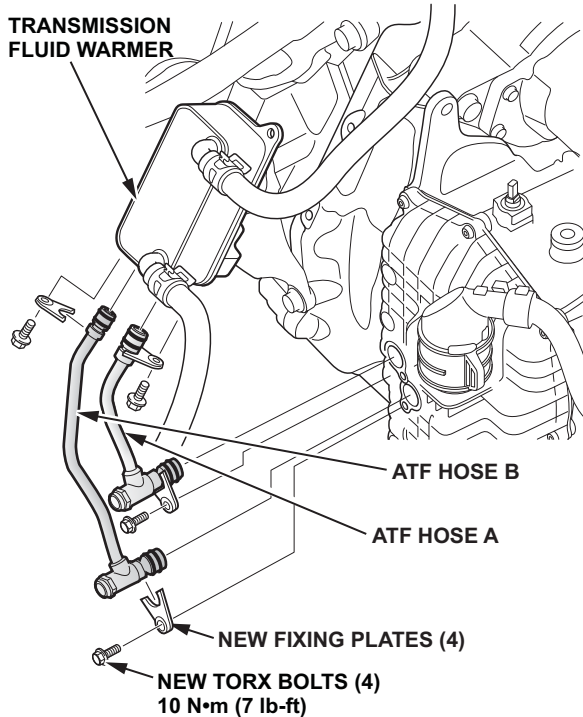

8. Slide the ATF cooler assembly up in front of the radiator as shown.

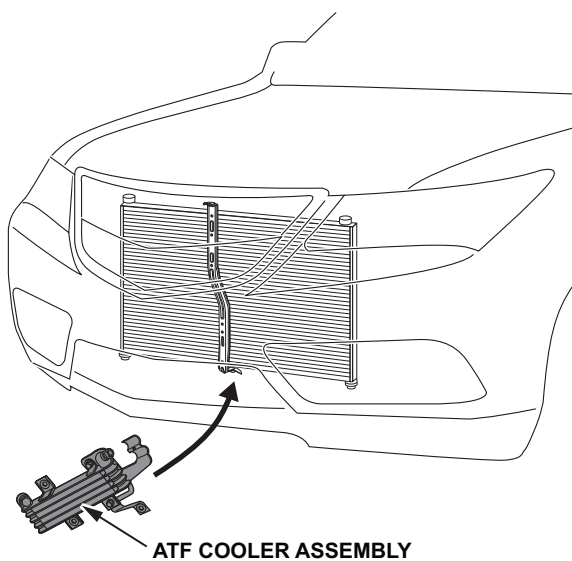

9. Install the ATF cooler with three 6 x 20 mm washer bolts.

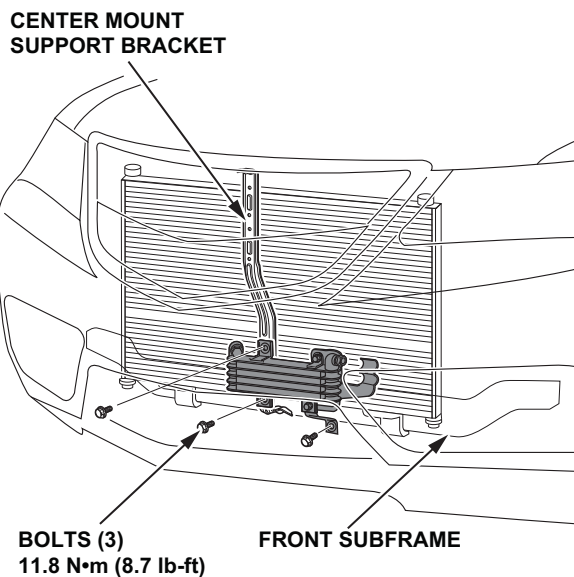

10. Install the transmission bracket with a 6 x 12 mm flange bolt.

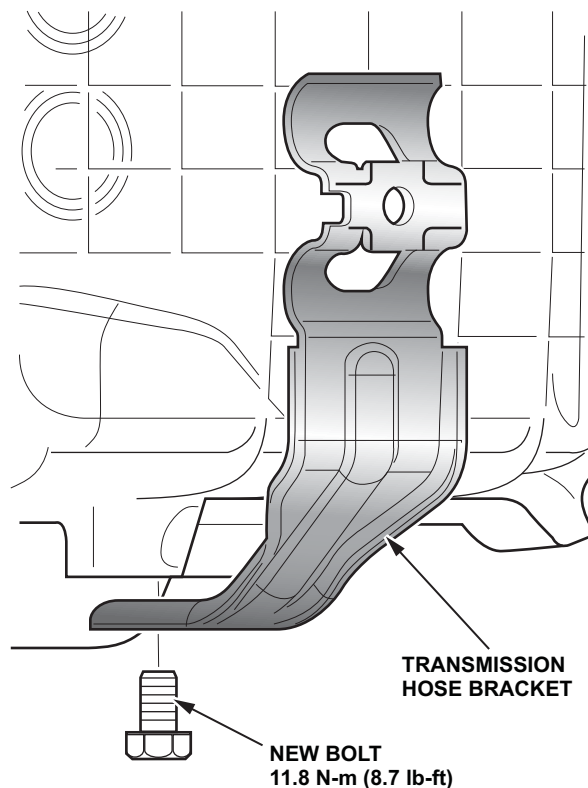

11. Install the four protective sleeves on the hoses as shown.

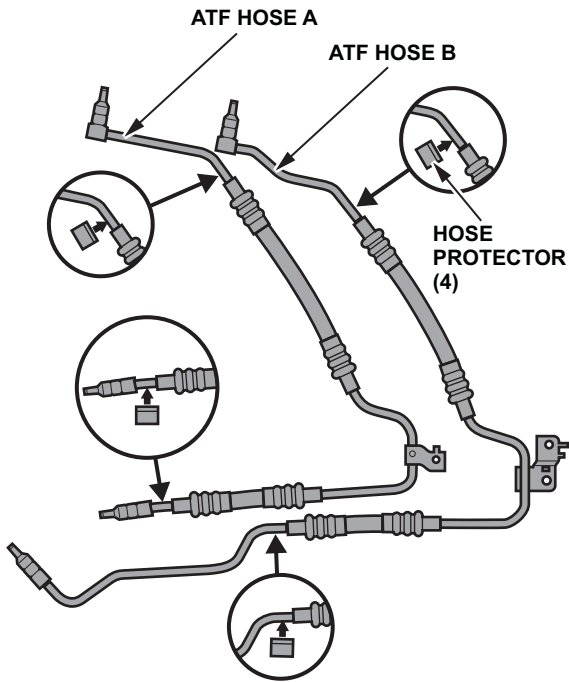

12. Connect ATF hose A to the ATF cooler and route the other end of the hose through the bulkhead.

**NOTE:**

- Quick connectors are one time use only and must be replaced if the quick connector, pipes, or snap rings are removed.
- Don't clean or lubricate the o-rings; they are lubricated when shipped. Don't allow any other fluids to come in contact with the o-rings.

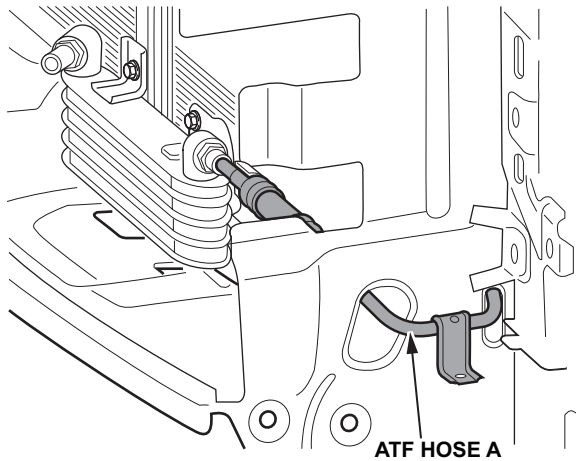

13. Connect ATF hose B to the ATF cooler and route the other end of the hose through the bulkhead.

**NOTE:**

- Quick connectors are one time use only and must be replaced if the quick connector, pipes, or snap rings are removed.
- Don't clean or lubricate the o-rings; they are lubricated when shipped. Don't allow any other fluids to come in contact with the o-rings.

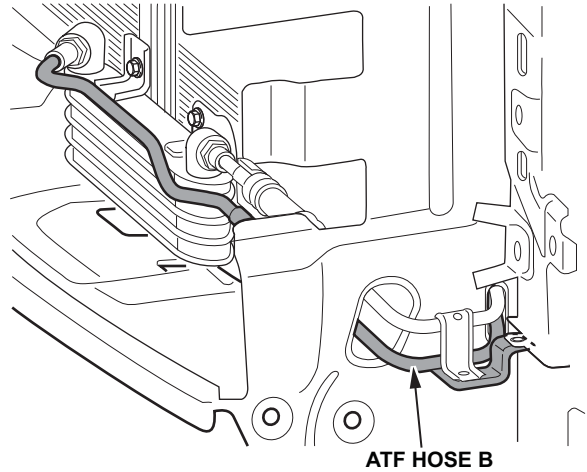

14. Install the hose bracket using a 6 x 16 mm washer bolt.

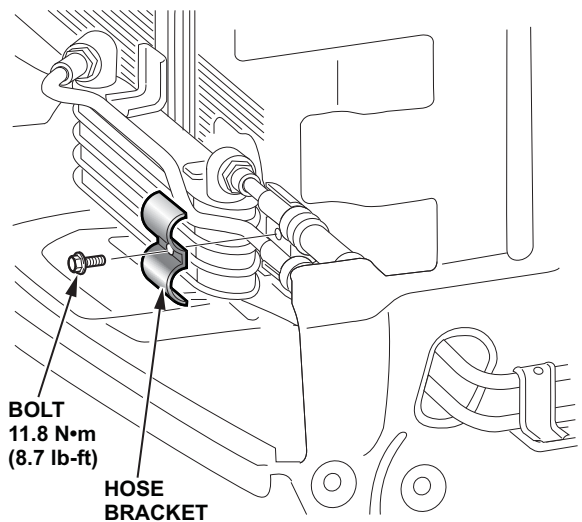

- Secure hose A and hose B to the bulkhead using the two 6 x 12 mm washer bolts.

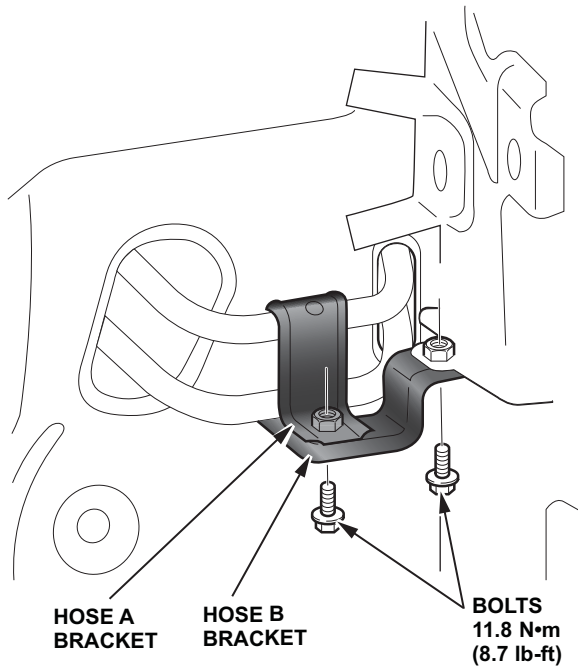

- Connect hose A to pipe A and hose B to pipe B.  
NOTE:
  - Quick connectors are one time use only and must be replaced if the quick connector, pipes, or snap rings are removed.
  - Don't clean or lubricate the o-rings; they are lubricated when shipped. Don't allow any other fluids to come in contact with the o-rings.

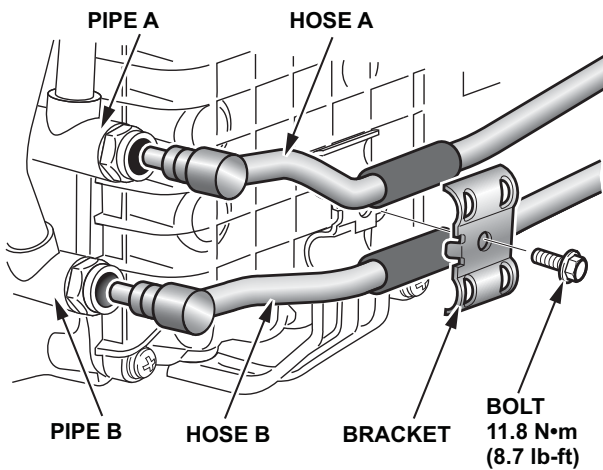

- Secure the hoses with the bracket using one 6 x 16 mm washer bolt as shown.

- Reinstall all removed parts.
- Inspect the ATF and adjust the fluid level as needed. Refer to the "ATF Level - Check" section of the electronic service manual.
- Install the hang-tag to the rear view mirror.
- Install the appropriate towing capacity label over the existing label.

